

80A02 EOS/ESD Protection Module Instructions

071-1317-00



www.tektronix.com



Safety Summary

To avoid potential hazards, use this product only as specified.

While using this product, you may need to access other parts of the system. Read the *General Safety Summary* in other system manuals for warnings and cautions related to operating the system.

To avoid fire or personal injury

Ground the product. This product is indirectly grounded through the grounding conductor of the mainframe power cord. To avoid electric shock, the grounding conductor must be connected to earth ground. Before making connections to the input or output terminals of the product, ensure that the product is properly grounded.

Observe all terminal ratings. To avoid fire or shock hazard, observe all ratings and markings on the product. Consult the host instrument documentation for further ratings information before making connections to the host instrument.

Do not apply a potential to any terminal, including the common terminal, that exceeds the maximum rating of that terminal.

Do not operate with suspected failures. If you suspect there is damage to this product, have it inspected by qualified service personnel.

Do not operate in wet/damp conditions.

Do not operate in an explosive atmosphere.

Keep product surfaces clean and dry.

Safety Terms In This Manual

CAUTION. Caution statements identify conditions or practices that could result in damage to the equipment or other property.

Safety symbols on the product



CAUTION
Refer to Product Manual

Product Description

The 80A02 EOS/ESD Protection Module protects the sensitive input stage of instruments (such as the sampling bridge of Tektronix electrical TDR sampling modules) from damages due to electro-overstress (EOS) and electro static discharge (ESD) from the device under test (DUT).

When used with the P8018 TDR probe, the 80A02 achieves static protection using normal probing procedures — no intentional user intervention (such as stepping on a foot switch) is required. This eliminates instrument damage due to human error in coordinating probing with control switching to achieve static protection.

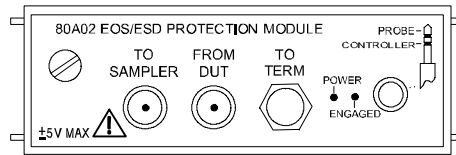

Figure 1: 80A02 EOS/ESD protection module

Installing and Removing the Module

Refer to the host instrument documentation for proper installation and removal of modules.

CAUTION. Instrument modules are extremely static sensitive. Always ground yourself when handling modules.

The module is designed to install directly into any available electrical sampling module slot of the following Tektronix sampling oscilloscopes:

- CSA8000 and TDS8000
- CSA8000B and TDS8000B
- CSA11K Series
- CSA800 Series

Connector Care

Use extra care when attaching or removing SMA connectors. Turn only the nut, not the cable. Align the connectors carefully before turning the nut. Use light finger pressure to make this initial connection. Then tighten the nut lightly with a wrench. Ideally, the SMA connectors should be tightened to 56 N-cm (5 in-lb) with a torque wrench.

Operation

The 80A02 protection module passes the test signal from the DUT to a sampling module, providing EOS and ESD protection to the input of the sampling module.

The FROM DUT connector of the protection module is initially held disconnected from the sampling module and terminated through a 50 Ω termination installed on the TO TERM connector, to remove EOS and ESD from the DUT. When the module is engaged, (via the control input), the signal is passed from the FROM DUT connector to the TO SAMPLER connector, and on to the sampling module.

CAUTION. No EOS or ESD protection is provided if the TO TERM connector is not terminated with the 50 Ω termination.

Figure 2 illustrates a typical configuration when using the 80A02 module with a Tektronix P8018 TDR Probe.

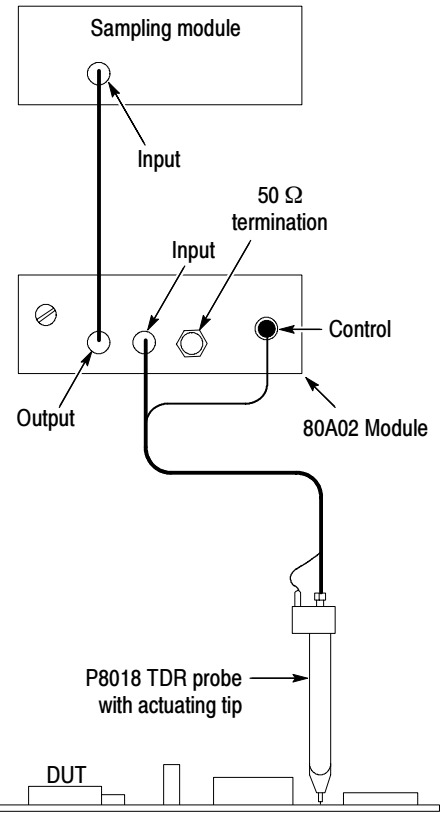

Figure 2: Typical module and probe use

Controlling the Module

The two methods for controlling the switching of the 80A02 module are Manual and Auto. A stereo phone input plug, when connected to the Probe controller input, can support both manual and auto control; a mono phone plug can support manual control only. See Figures 3 and 4.

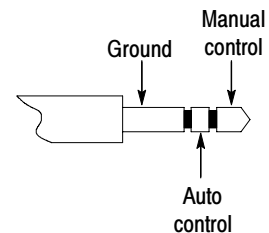

Figure 3: Stereo phone plug control sections

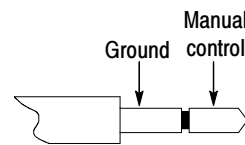

Figure 4: Mono phone plug control section

Manual Control. Manual control of the 80A02 module consists of either grounding or ungrounding the manual control section of either a stereo or mono mini phone plug.

- Ungrounded, the 80A02 module connects the

FROM DUT connector to the TO TERM connector, removing static charge.

CAUTION. No EOS or ESD protection is provided if the TO TERM connector is not terminated.

- Grounded, the 80A02 module connects the FROM DUT connector to the TO SAMPLER connector, passing the signal from the DUT along to a connected sampling module.

The Tektronix P8018 TDR probe provides manual control of the 80A02 module.

NOTE. When using a stereo phone plug to achieve auto control, the manual control section of the plug must be left open (no connections) to avoid accidentally engaging the 80A02 module.

Auto Control. Auto control of the 80A02 module consists of applying a logic low or high signal to the Auto control portion (middle conductor section) of a stereo phone plug (a mono phone plug cannot provide Auto control):

- With a logic low, the 80A02 module connects the FROM DUT connector to the TO TERM connector, removing static charge.
- With a logic high, the 80A02 module connects the FROM DUT connector to the TO SAMPLER connector, passing the signal from the DUT along to a connected sampling module.

NOTE. If using a stereo phone plug to establish Manual Control, the auto control section of the plug must remain open or grounded.

Functional Check

Use the following procedures to check the functionality of the 80A02 Protection Module.

Required equipment:

- Host instrument for 80A02 Protection Module
 - Stereo mini phone plug (with exposed connections)
 - 0 V to 5 V DC variable voltage supply
- Install the 80A02 Protection Module in an appropriate host instrument slot.
 - Insert the stereo mini phone plug into the PROBE CONTROLLER connector.
 - Check the manual control operation of the 80A02 module:
 - Identify the connection of the phone plug that is manual control portion of the phone plug. See Figure 5.
 - Short the manual control connection to ground.
 - Listen for the relay to operate in the 80A02 module and that the ENGAGED LED lights.
 - Disconnect the ground connection.
 - Check the auto control operation of the 80A02 module:
 - Identify the connection of the phone plug that is the auto control portion of the phone plug. See Figure 5.
 - Set the voltage supply to 0 V and connect the supply to the auto control connection.

- Check that the relay in the 80A02 module does not activate (no click sound) and that the ENGAGED LED does not light while adjusting the DC supply from 0 to 300 mV.
 - Check that the relay in the 80A02 module activates (click sound) and that the ENGAGED LED lights while adjusting the DC supply from 1 to 5 V.
 - Disconnect the voltage supply.
- Remove the mini phone plug.

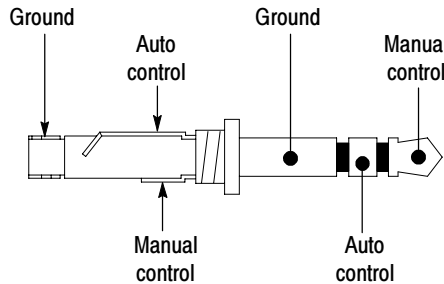

Figure 5: Typical stereo phone plug connections

Specifications

Table 1: Environmental and Mechanical

Characteristic	Specification
Weight	0.4 kg (0.6 lbs)
Dimensions	
Height	25 mm (1.0 in)
Width	79 mm (3.1 in)
Depth	135 mm (5.3 in)
Environmental conditions	Refer to the host instrument specifications
Temperature	
Operating	+10 °C to +40 °C Upper rating derates to +35 °C for all sampling modules on 2 meter extender cable
Non-operating	-22 °C to +60 °C
Humidity	
Operating	20% to 80% relative humidity with a maximum wet bulb temperature of +29 °C at or below +40 °C, non-condensing. (Upper limit derates to 45% relative humidity at +40 °C.)
Non-operating	5% to 90% relative humidity with a maximum wet bulb temperature of +29 °C at or below +60 °C, non-condensing. (Upper limit derates to 20% relative humidity at +60 °C.)
Altitude	
Operating	3,048 m (10,000 ft)
Non-operating	12,190 m (40,000 ft)
Electromagnetic Compatibility	Refer to the host instrument specifications for modular specifications

Table 2: Electrical

Characteristic	Specification
Applicable mainframes	TDS8000, CSA8000, TDS8000B, CSA8000B, CSA11800, and CSA803 mainframes
Number of channels	One
Channel connectors	Precision 26 GHz SMA female connectors
Interface connector	Stereophonic mini plug with the center conductor designated as the manual probe interface and outer conductor as the logic control interface
Input impedance	50 Ω
Absolute maximum input signal level (RF signals)	± 2 V peak
Module analog bandwidth	DC to 26 GHz
Manual control threshold (Auto control terminal unpowered)	Module engaged when manual control input has a resistive path to ground of <100 kΩ, open circuit for stand-by protection mode
Automated logic control threshold (Manual control terminal open)	<0.3 V: stand-by protection mode >1.0 V: Measurement engaged mode
Pilot lights	Power and engaged LED pilot lights indicate the corresponding states
Module switching time	20 ms typical 40 ms maximum

Accessories

The following items are included with the 80A02 Protection module:

- 80A02 Instructions 071-1317-xx
- SMA 50 Ω termination 015-1022-01
- 12 inch 20 GHz SMA cable 174-4878-xx

WARRANTY SUMMARY

Tektronix warrants that the products that it manufactures and sells will be free from defects in materials and workmanship for a period of one (1) year from the date of shipment. If a product proves defective within the respective period, Tektronix will provide repair or replacement as described in the complete warranty statement.

To arrange for service or obtain a copy of the complete warranty statement, please contact your nearest Tektronix sales and service office.

EXCEPT AS PROVIDED IN THIS SUMMARY OR THE APPLICABLE WARRANTY STATEMENT, TEKTRONIX MAKES NO WARRANTY OF ANY KIND, EXPRESS OR IMPLIED, INCLUDING WITHOUT LIMITATION THE IMPLIED WARRANTIES OF MERCHANTABILITY AND FITNESS FOR A PARTICULAR PURPOSE. IN NO EVENT SHALL TEKTRONIX BE LIABLE FOR INDIRECT, SPECIAL OR CONSEQUENTIAL DAMAGES.